

⚡ Specifications

Nominal Voltage(V)

2V

Nominal Capacity

10	hour rate	(60A	to	1.80V)	600Ah
5	hour rate	(102A	to	1.70V)	510Ah
1	hour rate	(360A	to	1.60V)	360Ah
1	C	(600A	to	1.60V)	300Ah

Weight

Approx. 36kg(79.2Lbs.)

Internal Resistance (at 1KHz)

Approx. 0.5 mΩ

Maximum Discharge Current for

5 seconds: 3600A

Charging Methods at 25°C(77°F)

Cycle use:	
Charging Voltage	2.33 to 2.36V
Coefficient -5.0mV/°C/cell	
Maximum Charging Current :	180A
Standby use:	
Float Charging Voltage	2.21 to 2.25V
Coefficient -3.0mV/°C/cell	

Operating Temperature Range

Charge	-15°C(5°F)	to	40°C(104°F)
Discharge	-15°C(5°F)	to	50°C(122°F)
Storage	-15°C(5°F)	to	40°C(104°F)

Charge Retention (shelf life) at 20°C(68°F)

1 month	98%
3 month	94%
6 month	85%

Case Material

ABS UL94 HB
Option: Flammability resistance of (UL94 V-0)

Design Life

12 Years.

Terminal

F18



⚡ Dimensions

Length (L)

241±3 (9.49±0.12)

Width (W)

172±3 (6.77±0.12)

Height (H)

329.5±3 (12.97±0.12)

Overall Height (HT)

340±3 (13.39±0.12)

Description of torque value of hard ware for the terminals:

Recommended torque value

M8:12 N-m (122kgf-cm)

Maximum allowable torque value

M8:20 N-m (204kgf-cm)
mm(inch)

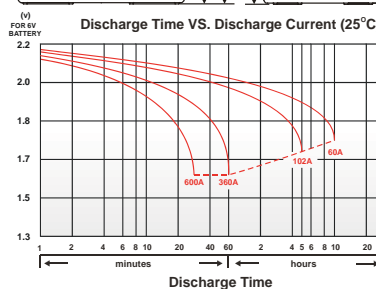
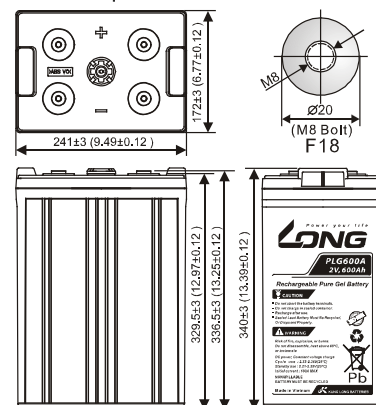

Effect of Temperature on Capacity 25°C(77°F)

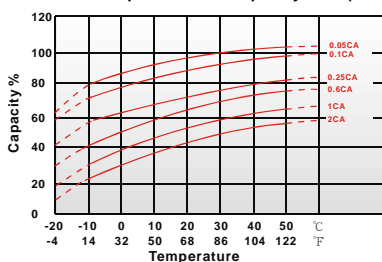

Capacity Retention Characteristic

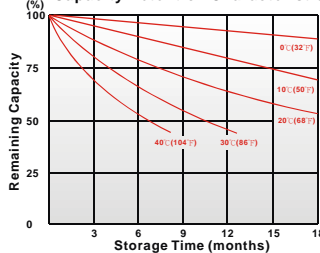

Cycle Service Life

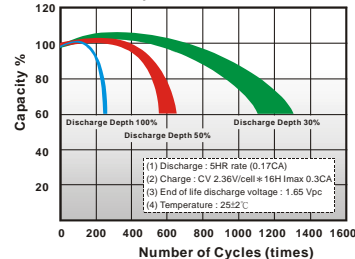

Trickle (or float) Service Life

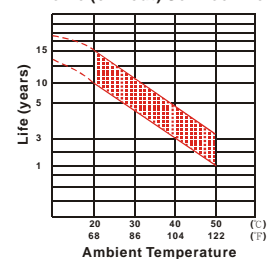

250522-1D